

USER MANUAL

Q.HOME CORE
H4/A4/H5/A5



Table of Contents

1	Information in this Manual	4
1.1	About This Manual	4
1.2	Target Group	4
1.3	Symbols Used in This Manual	4
2	Safety	5
2.1	Intented Use	5
2.2	Safety Precaution	5
2.3	Earth Fault Alarm	6
2.4	Product Safety Labels	6
2.5	Disposal	7
3	Product Description	8
3.1	Q.VOLT Overview	8
3.2	Q.SAVE Overview	9
3.3	Specifications	10
4	Power On/Off	12
4.1	Turnig On Q.HOME CORE	12
4.2	Using the Dark Start button	12
4.3	Turning Off Q.HOME CORE	13
5	LED Status	14
6	Using the Q.OMMAND HOME App	15
6.1	Getting Started	15
6.2	Main Menu Overview	16
6.3	Using the Dashboard Tab	16
6.4	Using the Overview Tab	17
6.5	Using the Report Tab	17
6.6	Changing the User Information	18
6.7	Viewing the Installation Information	18
6.8	Setting the Energy Backup	19

7	Operating Mode	20
7.1	ON-Grid Mode	20
7.2	Off-Grid Mode	22
7.3	Seamless Transfer	24
8	Features	25
8.1	Protection	25
8.2	Power Derating	25
8.3	Power Quality Response	25
8.4	Battery Management	26
8.5	Demand Response Modes (DRMS)	27
8.6	Dark Start	27
9	Maintenance	28
9.1	Cleaning the Cover	28
10	Full Warranty	29

1 Information in this Manual



1.1 About This Manual

This is the installation manual for Q.HOME CORE H4 / A4 / H5 / A5. Please read this installation and user manual carefully before installing and operating Q.HOME CORE H4 / A4 / H5 / A5. It contains important safety instructions. The warranty will be void if you fail to follow the instructions in this manual.

1.2 Target Group

Electricians and qualified technicians who are allowed to install and to connect electrical systems.

1.3 Symbols Used in This Manual

 WARNING	This symbol indicates a hazardous situation which could result in death or serious injury, if not avoided.
 CAUTION	This symbol indicates a hazardous situation which could result in minor or moderate injury, if not avoided.
	Prohibited.
Note	This indicates valuable tips for installation of the product.

2 Safety

The safety section may not include all regulations for your locale; personnel working with Q.HOME CORE H4/A4/H5/A5 must review applicable federal, state and local regulations as well as the industry standards regarding this product.

2.1 Intended Use

Q.HOME CORE H4/A4/H5/A5 is designed for residential use only. It should not be used for commercial or building. It is a single-phase, Grid-connected system of solar energy sources and Li-Ion Battery energy storage.

Q.HOME CORE H4/A4/H5/A5 uses solar energy power connected to the input/output terminal installed on the side of the device in order to:

- charge the Li-Ion Battery energy storage,
- provide a supply to the household load, and
- convert direct current (DC) electricity of the Battery to alternating current (AC) to discharge as household single-phase load or electric system.

This device should not be used for any purpose other than the purpose described in this installation manual. Any substitute use of this device, random change in any of its parts, and use of components other than sold or recommended by Q CELLS will nullify the product's guarantee.

For example, Q CELLS Li-Ion Battery energy storage should not be replaced by other manufacturer's Battery storages. For further information on proper use of this device, contact the Q CELLS Service-Hotline.

2.2 Safety Precaution

The following safety precautions and the warning messages described in this section must be observed. If any of the following precautions are not fully understood, or if you have any questions, contact the customer support for guidance.



- All work on the ESS and electrical connections must be carried out by qualified personnel only.
- High voltages in power conditioning circuits. Lethal hazard of electric shock or serious burns. Wear rubber gloves and protective clothing (protective glasses and boots) when working on high voltage/high current systems such as the inverter and battery systems.
- This product provides a safe source of electrical energy when operated as intended and as designed. But a potentially hazardous circumstance such as excessive heat or electrolyte mist may occur due to improper operating conditions, damage, misuse and/or abuse.
- Do not connect or disconnect PVs, batteries, and grid connectors with the power on. Otherwise, it may generate electric arcs or sparks, causing fire or injury.
- Do not open the enclosure while the inverter is operating. Touching live inner components may lead to electric shock, causing death or serious injury.
- Before maintenance, turn off the equipment and strictly comply with the safety precautions stated in this manual.



CAUTION

- This product is intended to be used for PV source inputs and residential home grids (AC 230V). If not used as intended, the protection provided by the equipment may be impaired.
- This product is designed appropriate for two-PV string structure. Therefore, the PV string 1 and PV string 2 must be connected to PV input 1 and PV input 2, respectively. Do not split one PV string output for connecting it into the PV input terminal 1 and input terminal 2.
- After disconnecting the inverter from the battery pack or PV, wait 5 minutes to discharge the inverter.
- Do not touch the PV cable when the product is connected to the PV arrays. When the photovoltaic array is exposed to light, it supplies DC voltage to the product.
- In case of short circuit, high-voltage components inside the inverter may influence the product or other properties. Cover the product or take other precautions to prevent metal objects from entering inside during installation and wiring.

2.3 Earth Fault Alarm

When an earth fault occurs, the inverter stops operation and the buzzer operates for 2 minutes.

Note: This feature is only supported on models released in Australia.

2.4 Product Safety Labels



Wear eye protection at all times (installation, maintenance, etc.)



Follow the instruction in this manual for service and replacement.



Caution: Risk of Electric Shock
 Alternating current (AC) and direct current (DC) sources are connected to this device. To prevent risk of electric shock during installation or maintenance, ensure that all AC and DC connections are disconnected.



Caution: Hot Surface
 Metallic parts of enclosure may be hot during operation.



Caution: Risk of Electric Shock
 Hazardous voltage is still present 5 minutes after all power sources have been disconnected. Wait for at least 5 minutes before maintenance to prevent electric shock.



Warning: Explosion
 Do not expose to heat or flame. Keep away from flammable substances.



Warning: Corrosive Substances Leaking
 Do not disassemble or modify the battery. Otherwise, corrosive substances may leak.

2.5 Disposal

Disposal of Q.VOLT



- When this crossed-out wheeled bin symbol is attached to a product, it means the product is covered by the European Directive 2002/96/EC.
- All electrical and electronic products should be disposed of separately from the municipal waste stream via designated collection facilities appointed by the government or the local authorities.
- The correct disposal of your old appliance will help prevent potential negative consequences for the environment and human health.
- For more detailed information about disposal of your old appliance, please contact your city office, waste disposal service or the shop where you purchased the product.

Disposal of Q.SAVE



- When this crossed-out wheeled bin symbol is attached to batteries/accumulators of your product, it means they are covered by European Directive 2006/66/CE.
- This symbol may be combined with chemical symbols for mercury(Hg), cadmium(Cd) or lead(Pb) if the battery contains more than 0.0005% of mercury, 0.002% of cadmium or 0.004% of lead.
- All batteries/accumulators should be disposed separately from the municipal waste stream via designated collection facilities appointed by the government or the local authorities.
- The correct disposal of your old batteries/accumulators will help to prevent potential negative consequences for the environment, animal and human health.
- For more detailed information about disposal of your old batteries/accumulators, please contact your city office, waste disposal service or the shop where you purchased the product.

3 Product Description

3.1 Q.VOLT Overview

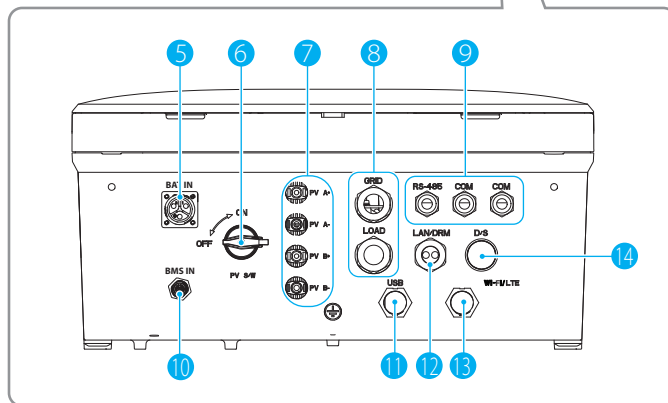
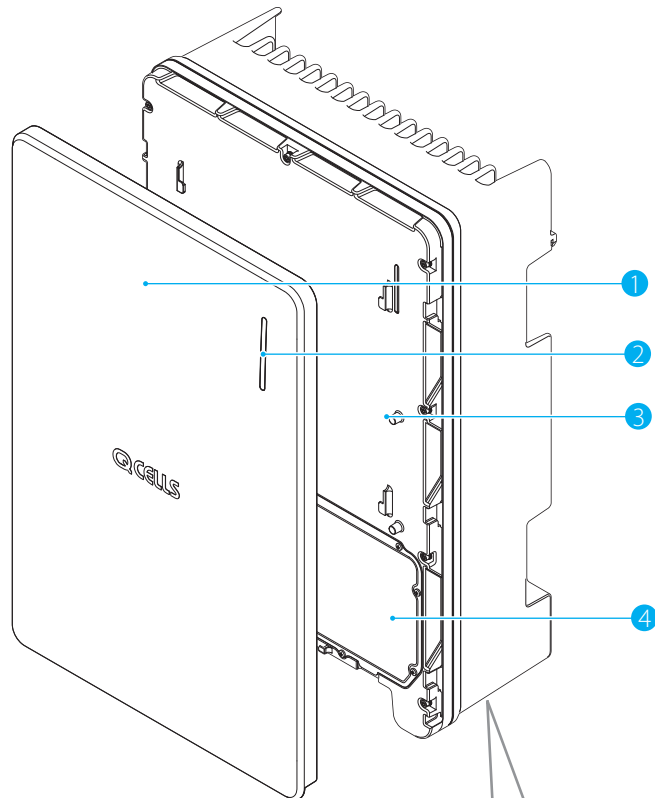

- 1 Front cover
- 2 LED indicator
- 3 Inner cover
- 4 Wiring cover
- 5 Battery power connector
- 6 PV switch
- 7 PV connector (H4 / H5 only)
- 8 Grid and Load port
- 9 Communication port
- 10 BMS Connector
- 11 USB Port
- 12 LAN / DRM port
- 13 Wi-Fi / LTE Dongle port
- 14 Dark Start switch

Note

For information about how to open the covers, refer to the installation manual.

3.2 Q.SAVE Overview

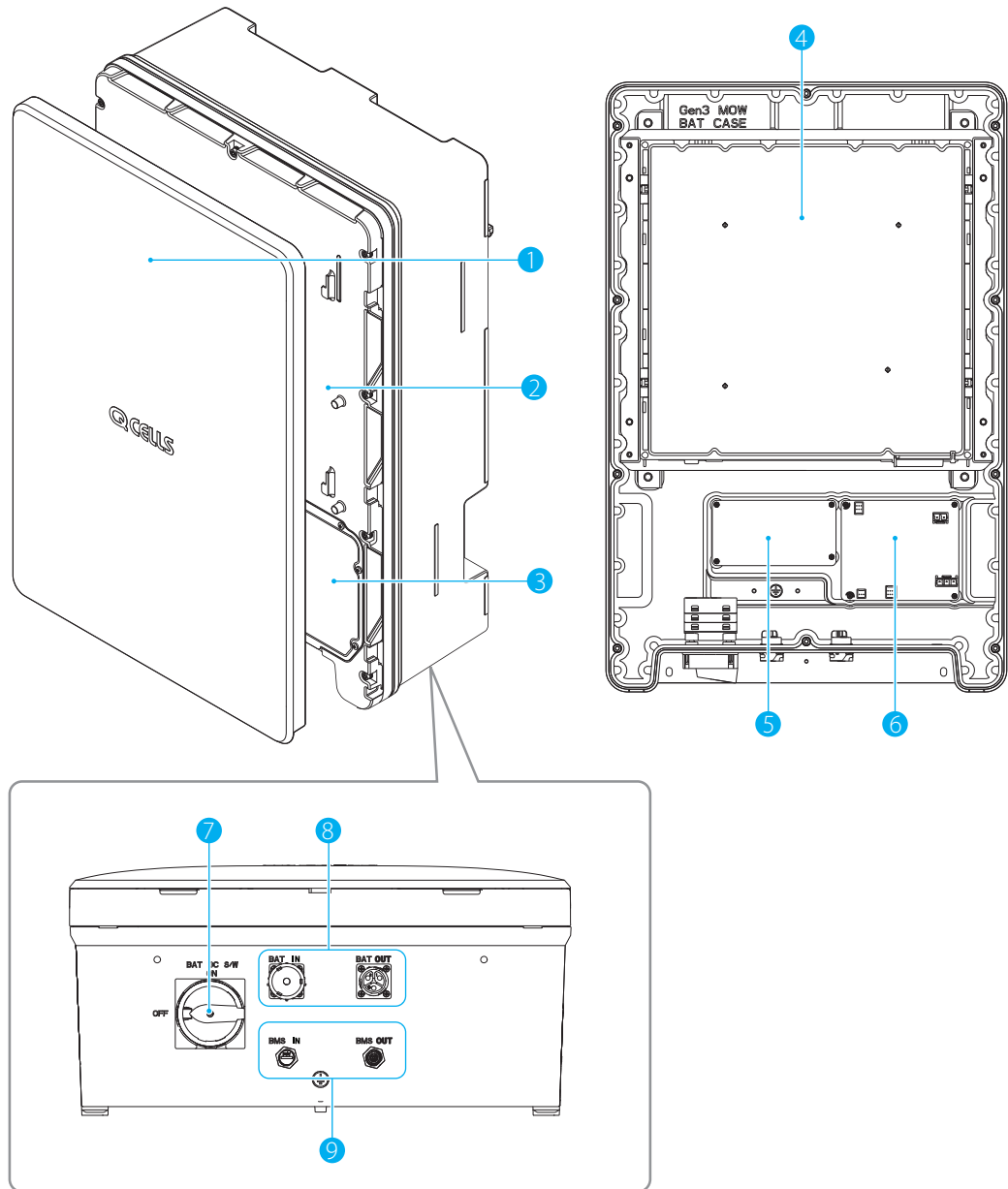

- 1 Front cover
 - 2 Inner cover
 - 3 Wiring cover
 - 4 Battery module
 - 5 Relay board
- 6 BMS board
 - 7 Battery DC Switch
 - 8 Battery Power Connector
 - 9 BMS Connector

3.3 Specifications

	H4	A4	H5	A5
GENERAL PRODUCT INFORMATION				
Dimensions Inverter Module / Battery Module (W × H × D) [mm]	460 × 700 × 221, 238 (From Wall)			
Weight Inverter Module / Battery Module [kg]	37.5/61.1	33.9/61.1	37.5/61.1	33.9/61.1
Operating Temperature Range [°C]	Q.VOLT: -20 to +60/Q.SAVE: -10 to +45			
Relative Humidity [%]	4 to 100 (Condensing)			
Protection Degree / Class	IP65			
Mounting	Wall-Mounted or Floor-Mounted Options			
Max. Operating Height without Power Loss [m]	2,000			
Cooling Method	Natural air cooling			
Product Warranty / Performance Warranty	15/15 years			
Noise Emissions	≤40 dB (A) @ 1m			
Over Voltage Category	OVC II (DC)/OVC III (AC)			
Communications	LAN, RS485, CAN, Wi-Fi(optional), LTE(optional)			
Remote Monitoring	Web, Mobile & App			
Software Update	Online update			
Energy Management System	Integrated			
PV DATA (DC)				
Max. Input Usable Power [kWp]	8.0 (4.0 per MPPT)	N/A	8.0 (4.0 per MPPT)	N/A
Max. Input Voltage [V _{DC}]	600		600	
Start Input Voltage / MPP Voltage Range [V]	120/90 to 550		120/90 to 550	
Number of Independent MPPTs	2		2	
Number of DC Input Pairs per MPPT	1		1	
Max. Input Current per MPPT / Max. Short Circuit Current per MPPT [A]	15/20		15/20	
DC Connection Type	MC4		MC4	
GRID DATA (AC)				
Max. Apparent Power / Rated Output Power [kVA/kW]	5 (4.6 for DE)/5 (4.6 for DE)		5/5	
Nominal Voltage / Range [V]	230/184 to 264		230/180 to 260	
Nominal Grid Frequency / Range [Hz]	50, 60/ -5Hz to +5Hz			
Feed-in Phases / Connection Phases	Single / Single			
Nominal Current / Max. Current / Max. Over-Current Protection [A]	21.7 / 25 / 30 (20 / 25 / 30 for DE)		21.7 / 25 / 30	
Power Factor Range	0.95 lagging to 0.95 leading		0.8 lagging to 0.8 leading	
Total Harmonic Distortion [%]	≤5			
BACKUP POWER OUTPUT (ALTERNATING CURRENT)				
Connection Phases	Single			

	H4	A4	H5	A5
Rated Apparent Power / Rated Power(Only Battery) [kVA / kW]	3.3 to 4.5/ 3.3 to 4.5 @ 1 Battery Pack 5/5 (DE: 4.6) @ 2 Battery Pack	3.3 to 4.5/ 3.3 to 4.5 @ 1 Battery Pack 5 (DE: 4.6)/ 5 (DE: 4.6) @ 2 Battery Pack	3.3 to 4.5/3.3 to 4.5 @ 1 Battery Pack 5/5 @ 2 Battery Pack	
Rated Apparent Power / Rated Power (With PV) [kVA / kW]	5 (4.6 for DE) / 5 (4.6 for DE) (max)		5/5 (max)	
Rated Voltage [V]	230			
Rated Frequency [Hz]	50, 60			
Switch over Time to Backup Power	less than 0.1 seconds			
Support by PV during Backup Power Operation	YES			
EFFICIENCY				
MPPT Efficiency [%]	99.9	N/A	99.9	N/A
Max. Efficiency (PV to Grid) [%]	97		97	
Max. Efficiency (PV to Battery) [%]	97.8		97.8	
Max. Efficiency (Battery to Grid) [%]	96.3			
BATTERY UNIT (DC)				
Battery Technology	Lithium-ion			
Battery Energy [kWh]	6.8 / 13.7 / 20.5 (6.86 kWh / pack)			
Battery Usable Energy [kWh]	6.51 / 13.03 / 19.55			
Max. Charge Power [kW]	2.8 to 3.8 @ 1 Battery Pack 5 @ 2 Battery Pack	2.8 to 3.8 @ 1 Battery Pack 5 (DE: 4.6) @ 2 Battery Pack	2.8 to 3.8 @ 1 Battery Pack 5 @ 2 Battery Pack	
Max. Discharge Power [kW]	3.3 to 4.5 @ 1 Battery Pack 5 (DE: 4.6) @ 2 Battery Pack		3.3 to 4.5 @ 1 Battery Pack 5 @ 2 Battery Pack	
Converter Technology	Non-isolated			
Rated Battery Voltage / Battery Voltage Range [V _{DC}]	202.8 / 168.0 to 228.2			
Maximum Charge / Discharge Current [A]	16.9 / 20			
Depth of Discharge (DoD) [%]	95			
CERTIFICATES AND APPROVALS				
Inverter Model Name	Q.VOLT H4.6S	Q.VOLT A4.6S	Q.VOLT H5S	Q.VOLT A5S
Battery Model Name	Q.SAVE B6.8S			
Certificates and Approvals	VDE-AR-N 4105:2018, CE, IEC 62109-1, IEC 62109-2, IEC 62040-1, IEC 62619, IEC 62477-1, EN 61000-6-2, EN 61000-6-3, IEC 60068.2- 52, EN 60730-1 ANNEX.H		AS/NZS 4777.2:2020, CE, IEC 62109-1, IEC 62109-2, IEC 62040-1, IEC 62619, IEC 62477-1, EN 61000-6-2, EN 61000-6-3, IEC 60068.2- 52, EN 60730-1 ANNEX.H	

4 Power On/Off

4.1 Turnig On Q.HOME CORE

To turn on the Q.HOME CORE:

- 1 Turning on the AC circuit breaker.
- 2 Turning on the PV switch.

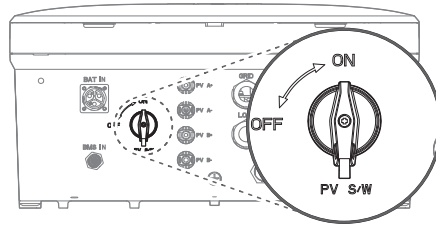

- 3 Turning on the battery DC switch.

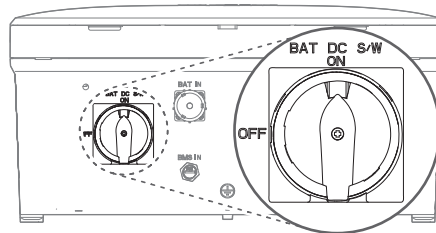

4.2 Using the Dark Start button

To turn on Q.HOME CORE when there are no PV and Grid:

Press the **Dark Start** button for about 10 seconds.

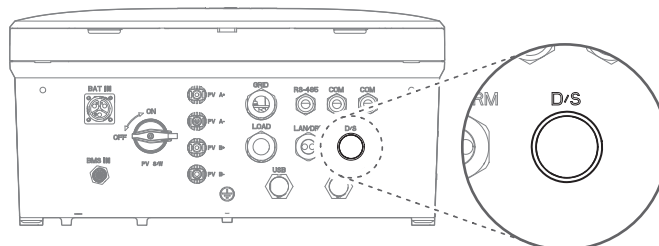

- Once the power is supplied and the LED turns blue, release the Dark Start button.
- Once the inverter enters the Off-grid mode and starts operation, the LED turns green.

4.3 Turning Off Q.HOME CORE



If the AC circuit breaker cannot remain switched on after commissioning (e.g. because the new meter has not yet been installed), the DC switch on the hybrid inverter must remain switched on to avoid deep discharge of the battery. Alternatively, the device can also be switched off completely.

To turn off the Q.HOME CORE:

- 1 Turning off the battery DC switch.

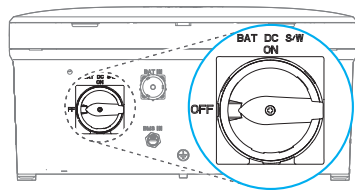

- 2 Turning off the PV switch.

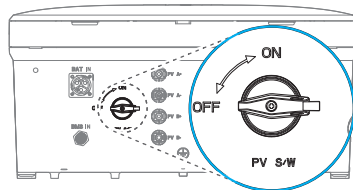

- 3 Turn off the AC circuit breaker in the junction box.



Note







After turning off the Q.HOME CORE, the DC and PV switches can be locked for safety.

For details about locking the DC and PV switched, see "16 Power Off" in the installation manual.

5 LED Status

After turning on the Q.HOME CORE, check the status of the LED indicator on the front.

The meanings of the LEDs by color and behavior are as follows:

LED Color	LED Behavior	Description
 Sky Blue	Solid	Charging or discharging in online mode
	Flashing	Standby in online mode
 Magenta	Solid	Charging or discharging in offline mode
	Flashing	Standby in offline mode
 Green	Solid	Charging or discharging in off-grid mode
	Flashing	Standby in off-grid mode
 Blue	Solid	All operations are paused
 Red	Solid	Major and minor error status
	Flashing	Critical error status
 Yellow	Solid	Setup in progress
	Flashing	Connecting to the network
 White	Solid	Upgrading firmware

6 Using the Q.OMMAND HOME App

6.1 Getting Started

Search and install Q.OMMAND HOME on the Apple AppStore or Google Play Store.

Log In

When you install and run the app initially, you have to select the server to access.

Then, when you run it again, it starts from the login step (Step 3).

- 1 Select the server to access between Australia and Europe.



- 2 Tap **SAVE**.

- 3 Enter your ID and password and tap **LOGIN**, or use a social login.



Note

If you don't have your account yet, select "**Don't Have an Account? Register**" at the bottom of the login screen to register for membership. You can also select a social login to register for membership.

Sign Up

- 1 Read and agree to the terms and conditions.

- 2 Tap **NEXT**.

- 3 Enter your name, Home ID, ID and password.

- Home ID is the household identification number and necessary information when creating your user account and is provided by the installer.

- 2 Tap **SAVE**.

Log Out

- 1 Tap  on the right top of the screen.
- 2 Tap **Logout**.

6.2 Main Menu Overview



- 1 **Dashboard:** Provides a variety of real-time information about the system.
- 2 **Overview:** Provides various usage analysis information.
- 3 **Report:** Provides hourly, daily and monthly history for energy usage.

6.3 Using the Dashboard Tab

Energy Flow & Inventory



Flow: Updates the PV generation amount, the battery charging/discharging amount, the household power consumption amount, and the grid system power information every 3 seconds. You can view the current household energy flow at a glance.

Inventory: Shows the current PV/battery capacity installed in the household.

Live Load



Updates the household power consumption every 3 seconds.

Today Chart



Visualizes today's generation and consumption amounts (24 hours)
Top numbers indicate cumulative values of respective charts.

You Saved



Shows how much power is saved in % or amount (\$, €, etc.).

- To change the cost unit, tap the unit .

6.4 Using the Overview Tab

The **Overview** tab shows the power usage pattern of the month compared to that of the same month of the previous year.



- **Generation:** PV generation amount
- **Consumption:** Household power consumption amount
- **Charging:** Battery charging amount
- **Discharging:** Battery discharging amount
- **Feedin:** Power sales to the grid system
- **Demand:** Power purchase from the grid system

6.5 Using the Report Tab



The **Report** tab provides hourly, daily and monthly history for Generation, Consumption, Feedin, Demand, Charge, Discharge, and the detailed information of Battery SOC (State of Charge, 0%: empty, 100%: full).

- Battery SOC is provided only in the hourly report.
- Tap the calendar  to select the date.

6.6 Changing the User Information

1 Tap  on the right top of the screen.

2 Tap **User Info.**

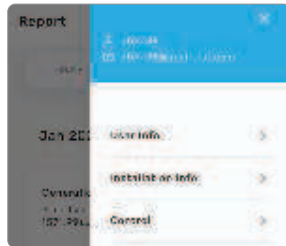

3 Change the desired item (E-mail, password, etc.).

4 Tap **SAVE.**

6.7 Viewing the Installation Information

1 Tap  on the right top of the screen.

2 Tap **Installation Info.**

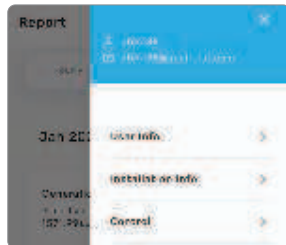

3 Select the desired tab.

- **Product:** Provides the product information such as the serial no., Home ID, etc.
- **Installer:** Provides the contact information for the installer.
- **Address:** Provides the installation location

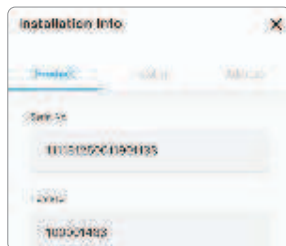

6.8 Setting the Energy Backup

The charging amount of the battery should be maintained above a certain range considering situations such as blackout. By setting the Energy Backup option, you can set the battery to discharge only up to the specific amount under normal circumstances and backup energy can be used when blackout occurs.

To set the energy backup:

1 Tap  on the right top of the screen.

2 Tap **Control**.

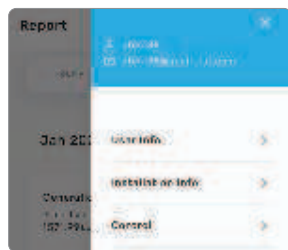

3 Tap **Edit**.

4 Adjust the slider or enter the value (%) for the energy backup.

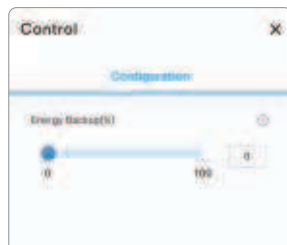

5 Tap **Save**.

7 Operating Mode

7.1 ON-Grid Mode

Daytime On-Grid

- **PV Power > Load Power:** The PV power is preemptively supplied to the household load (Critical load + Main Load), and then it charges the battery. If PV energy remains, it is operated according to the operation mode as below.
 - **Self consumption mode:** The remaining PV energy is supplied to Grid.
 - **Zero export mode:** Q.VOLT decreases the PV generation amount.
- **PV Power < Load Power:** If the PV power is less than the household load (Critical load + Main Load) power, the battery discharges to provide the short household load energy. If the PV + battery power is less than the load power, the short load power is supplied from the grid system.

H4 / H5

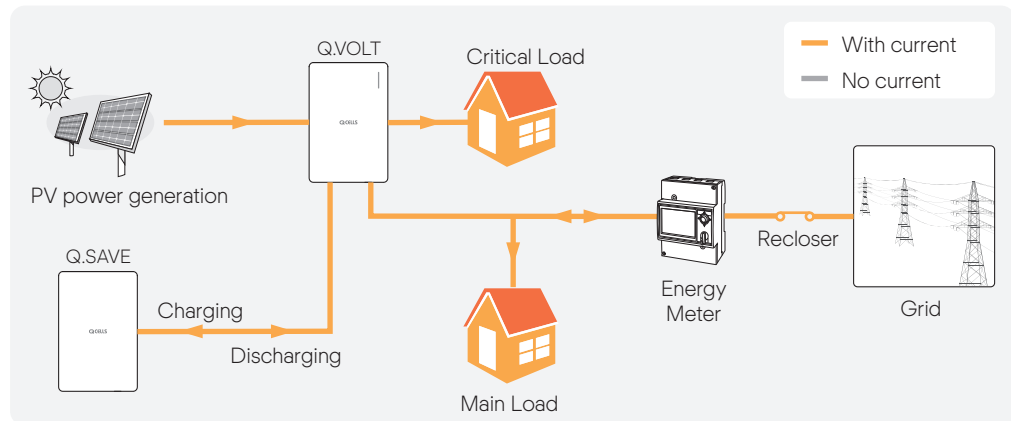

A4 / A5

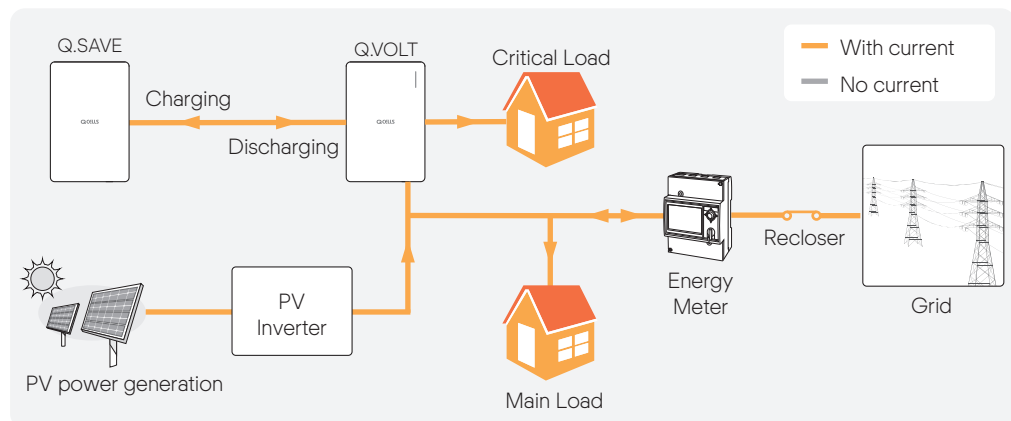

Nighttime On-Grid

While the battery discharges, it supplies energy to the load. If the battery power is not enough to supply energy to the household load (Critical load + Main Load), the short power is supplied from the grid system.

H4 / H5

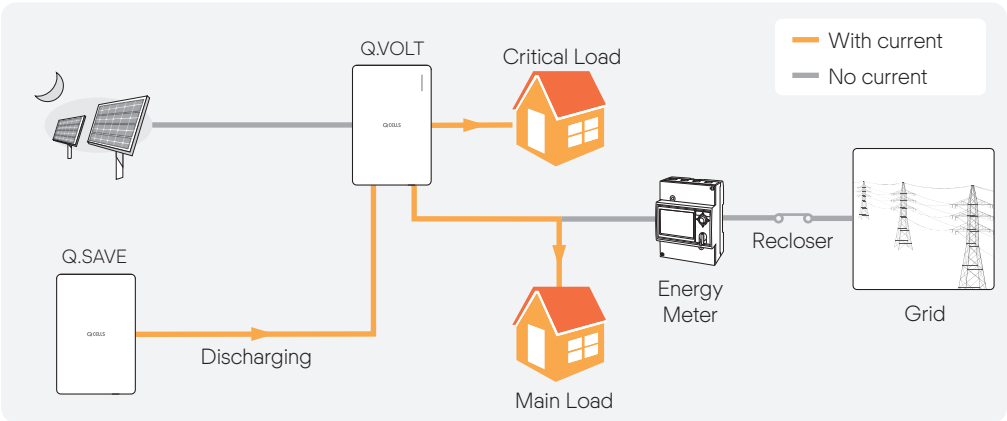

A4 / A5

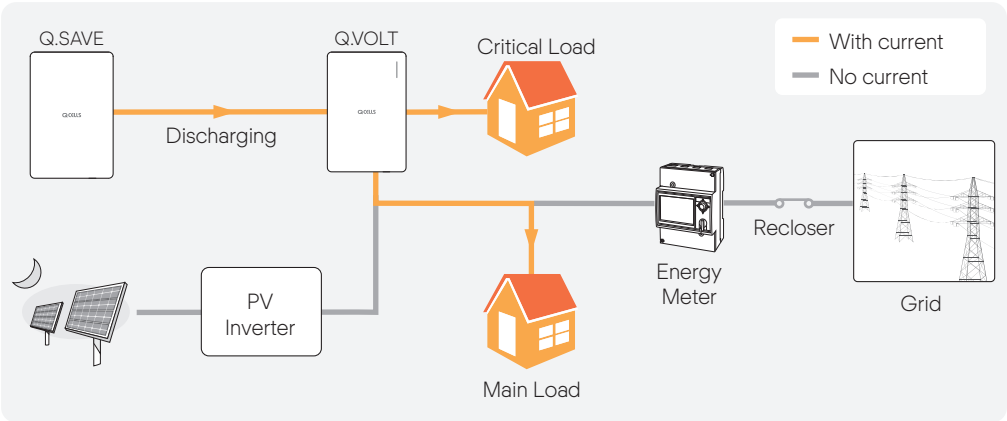

7.2 Off-Grid Mode

Daytime Off-Grid

- **PV Power > Load Power:** The PV power is preemptively supplied to the household load (Critical Load), and then it charges the battery. Then, when the battery is fully charged, the inverter lowers the PV power to generate as much as the household load (Critical load) power.
- **PV Power < Load Power:** If the PV power is less than the household load (Critical load + Main Load) power, the battery discharges to supply the short energy to the critical load. If PV + battery power is less than the load power, the inverter stops operating.

H4 / H5

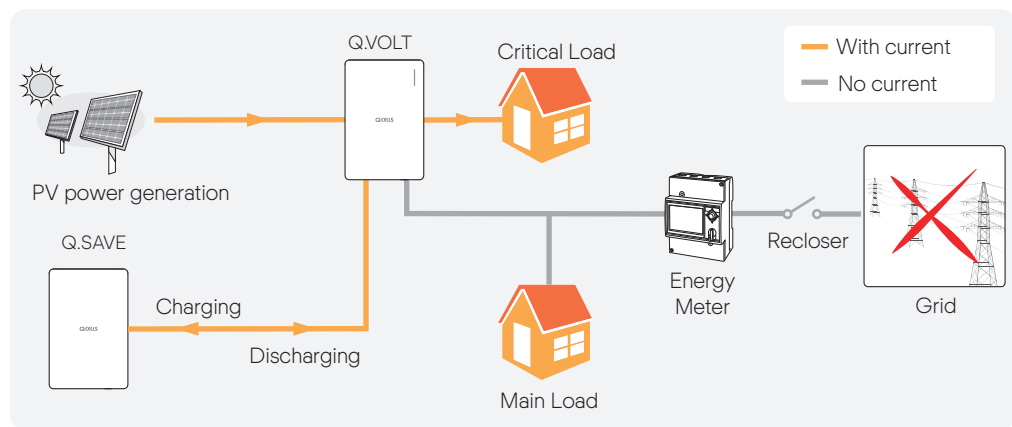

A4 / A5

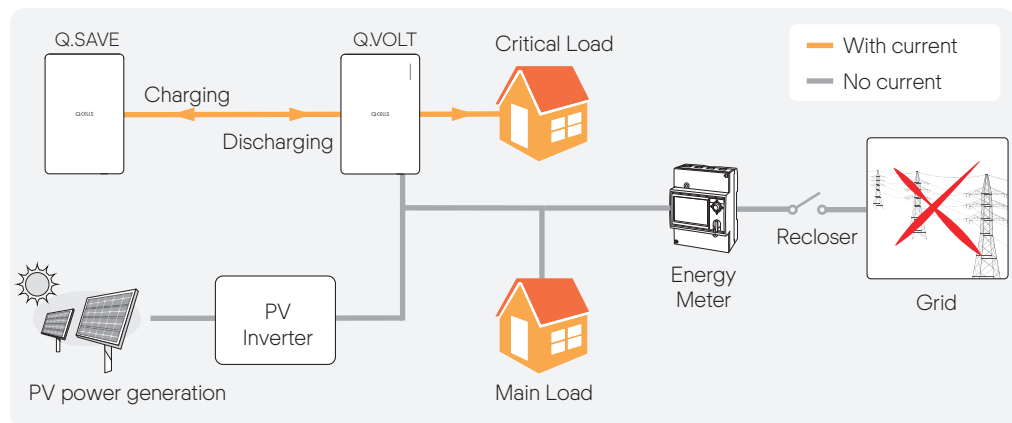

Nighttime Off-Grid

While the battery discharges, it supplies energy to the load. If the battery power is not enough to supply energy to the household load (Critical Load), the inverter stops operating.

H4 / H5

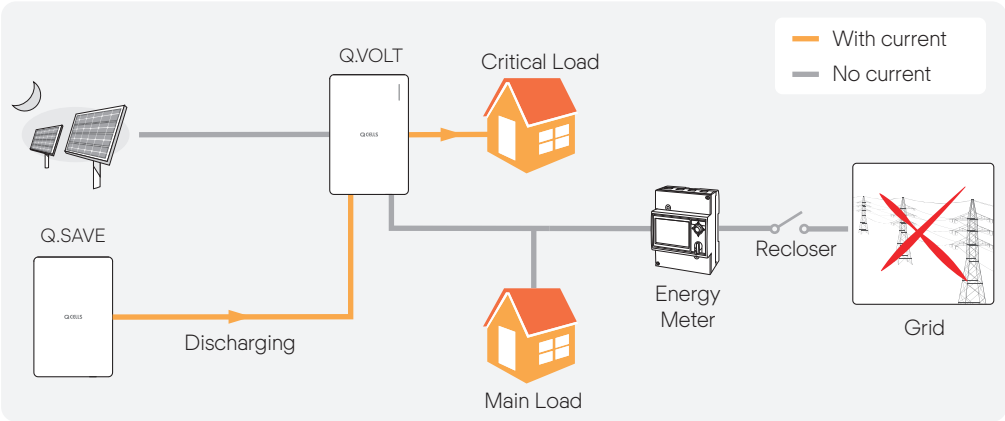

A4 / A5

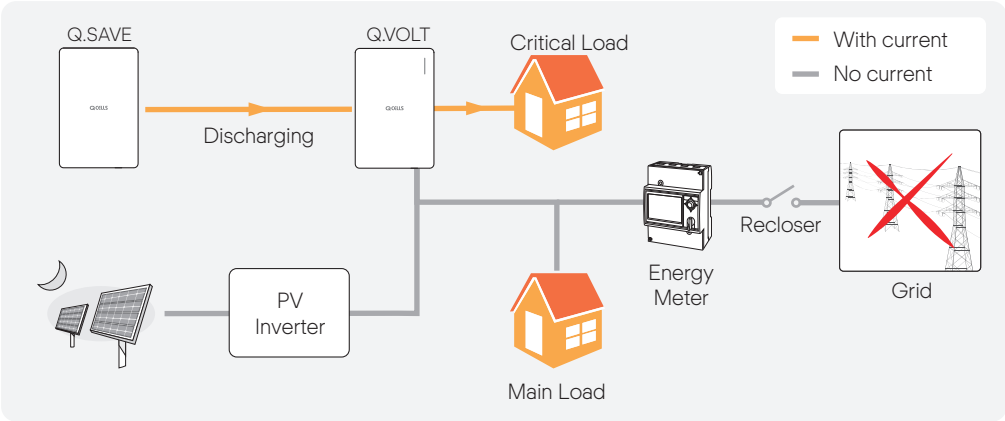

7.3 Seamless Transfer

- **On-grid → Off-Grid:** If disconnected due to a grid system failure during the on-grid operation, the inverter is disconnected from the grid system automatically and supplies power to the critical load seamlessly.
- **Off-grid → On-Grid:** If the grid system power is restored during the off-grid operation, the inverter is automatically connected to the grid system after a certain period and operates in the on-grid mode.

H4 / H5

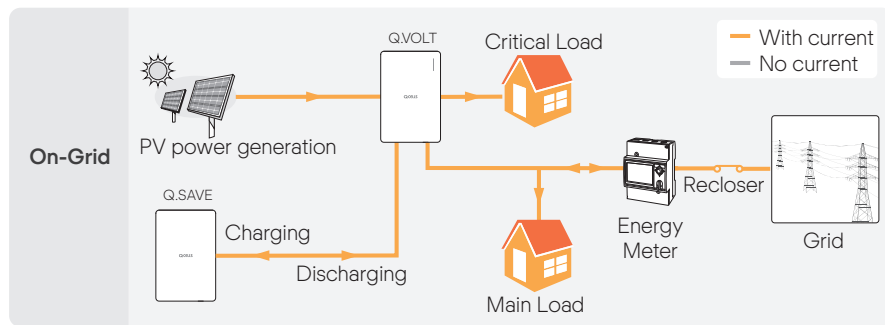

Seamless Transfer

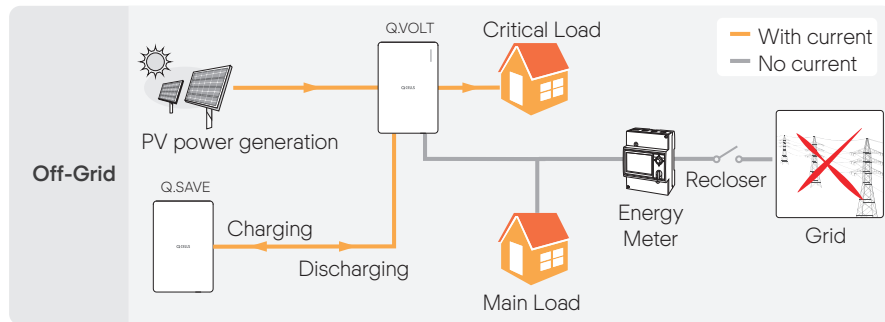

A4 / A5

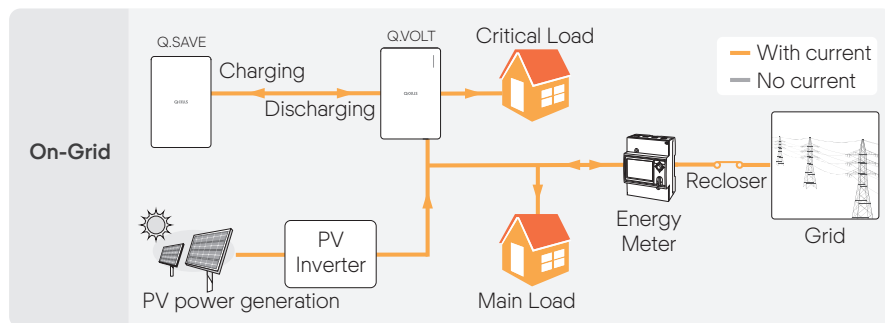

Seamless Transfer

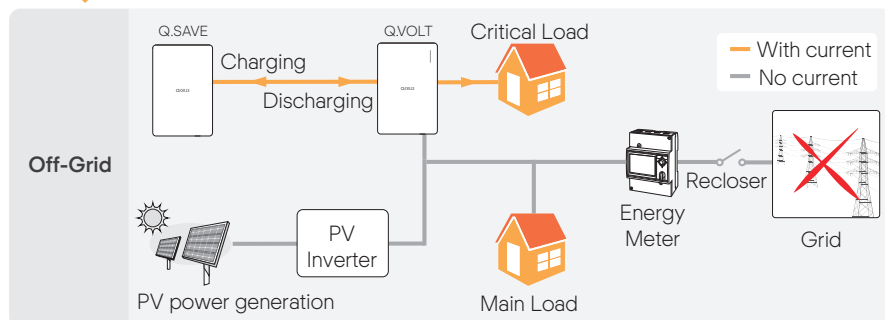

8 Features

8.1 Protection

Q.HOME Core has the following protective features to prevent equipment and persons from being damaged due to external accidents or equipment failure:

- Short circuit protection
- Over voltage / over current
- Over temperature
- Insulation resistance surveillance
- Residual current protection
- Anti-islanding protection

8.2 Power Derating

Q.HOME Core limits the output power on over-temperature to protect the inverter from overload or other potential errors. If the temperature does not drop beyond a certain period, the inverter stops its operation.

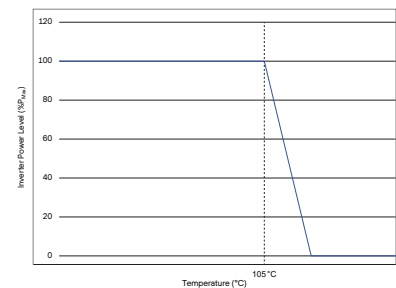

8.3 Power Quality Response

• **Active Power Response:** The inverter supports the active power response mode according to the grid code to support the grid system.

- **Volt-Watt:** The input and output active powers are limited by the response curve according to the inverter operation mode (charging and discharging) and the grid system voltage. This response is supported only in Australia and New Zealand.

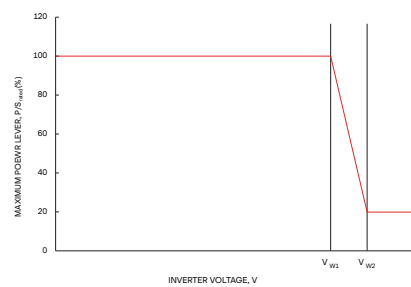
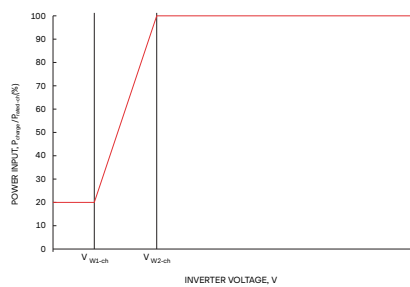

- **Frequency-Watt:** The input and output active powers change by the response curve according to the inverter operation mode (charging and discharging) and the grid system frequency. This response is supported only in Australia, New Zealand, and Germany.

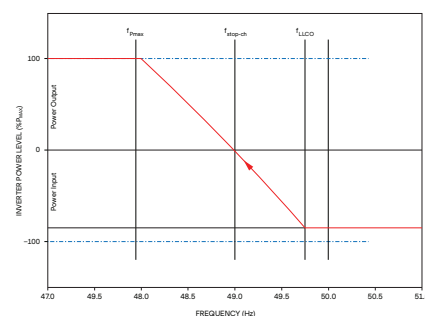
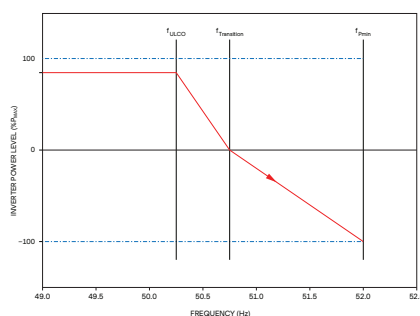

- **Reactive Power Response:** The inverter supports the reactive power response mode according to the grid code to support the grid system.

- **Volt-var:** The inverter outputs the reactive power by the response curve according to the grid system voltage. This response is supported only in Australia and New Zealand.

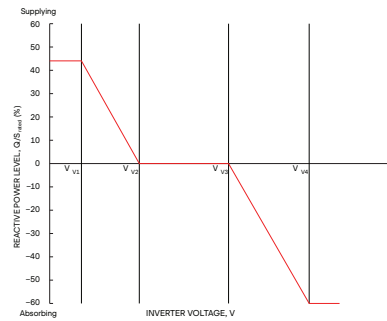

- **Cos Φ (P) curve:** If the output power is generated 50% or higher, the inverter outputs the lagging reactive power according to the active power response curve. This response is supported only in Germany.

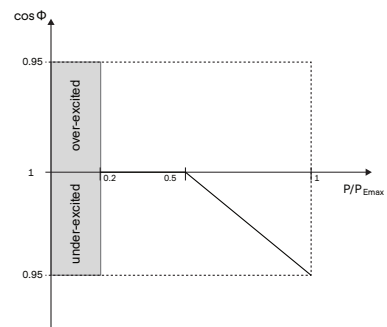

8.4 Battery Management

- **Backup SOC:** The minimum SOC that the battery maintains in order to supply power to the load in the case of Off grid.
 - Battery SOC < Backup SOC (On-grid mode): Q.HOME CORE does not discharge the battery but only performs charging operation.
- **Charge Management:** If the PV power is greater than the load power, the inverter charges the battery. If the battery SOC reaches 100 %, the battery converter stops its operation not to be overcharged.
- **Discharge Management:** Discharge Management effectively prevents the battery from being damaged due to overcharge. If the battery SOC (State of Charge) reaches 5 % or the Backup SOC, it limits the battery discharge.
- **Cell balancing:** If the inter-cell potential difference exceeds the threshold voltage, the PCS automatically starts cell balancing control to prevent the battery from damage due to the potential difference among battery cells.
- **Parallel Connection:** In the Q.SAVE parallel connection, internal module relays is not connected if voltages are different between each battery module. Then, the battery management system automatically controls charging/discharging power of each battery to achieve the identical Q.SAVE voltage. When the voltage of each module becomes equal, the internal relays are connected.

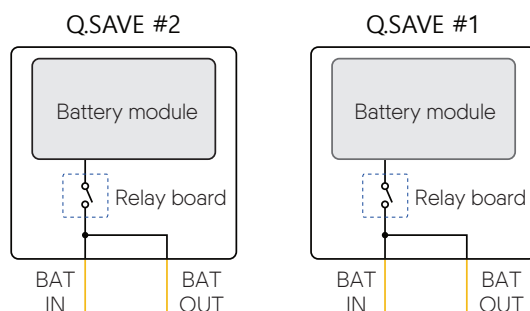

- **Power derating:** It limits the charging/discharging power on over-temperature/under-temperature to protect the battery from overload or other potential errors. If the temperature does not drop beyond a certain period, the BDC stops its operation.

8.5 Demand Response Modes (DRMS)

The inverter supports the DRM (Demand Response Mode) function as specified in AS 4777.2 2015.

Mode	Description
DRM 0	The inverter is in the state of "Key-stop."
DRM 1	The import power from the grid is 0.
DRM 2	The import power from the grid is no more than 50 % of the rated power.
DRM 3	The import power from the grid is no more than 75 % of the rated power.
DRM 4	The import power from the grid is no more than 100 % of the rated power, but subject to the constraints from other active DRMs.
DRM 5	The export power from the grid is 0.
DRM 6	The export power from the grid is no more than 50 % of the rated power.
DRM 7	The export power from the grid is no more than 75 % of the rated power.
DRM 8	The export power from the grid is no more than 100 % of the rated power, but subject to the constraints from other active DRMs.

8.6 Dark Start

Dark Start feature allows you to turn on Q.HOME CORE when there are no PV and Grid:
For details about how to use the Dark Start, see "4.2 Using the Dark Start button" on page 12.

Note

In case of Dark Start, if the battery SOC is below 5%, Q.HOME CORE stops its operation and is turned off again.

9 Maintenance

9.1 Cleaning the Cover



Qualified Person Only!

If Q.HOME CORE is dirty, clean the enclosure, the enclosure cover and the LED using only clean water and a soft cloth.

Ensure that the Q.HOME CORE is free of dust, foliage and other dirty.

10 Full Warranty

Download the Q.HOME CORE warranty document from the QCELL web page or the following link (or the QR code), and make sure to read it carefully.

MEMO

MEMO

Q.HOME ESS Service for Europe, Germany

E-Service Haberkorn GmbH, Augustenhöhe 7, 06493 Harzgerode

TEL +49 (0)39484 9763 85

EMAIL q.home@e-service48.com

Hanwha Q CELLS Australia Pty Ltd

Suite 1, Level 1, 15 Blue Street, North Sydney NSW 2060 Australia

TEL +61 (0)2 9016 3033

EMAIL qhome.au@q-cells.com

Hanwha Solutions Corp.

Q CELLS 86 Cheonggyecheon-ro Jung-gu
Seoul Korea 04541